

## CAR AND LIGHT TRUCK INSTALLATION

### GUIDE

PLEASE READ **ALL** INSTRUCTIONS BEFORE YOU BEGIN.

1. Raise vehicle hood. Locate air intake tube. This tube goes from the air box cover to the throttle body.
2. Loosen the clamp that holds the tube to the air box cover. Disconnect intake tube from air box cover.
3. Determine where Economaxx will friction fit in hard plastic of intake tube. Drill a 5/32 inch pilot hole in hard plastic. Take precaution to ensure plastic shavings do not go down intake tube. Insert Economaxx with small end facing the throttle body using a friction fit. Secure with provided hardware
4. Reinstall air intake tube to air box cover and tighten clamp.
5. If the Economaxx does not friction fit into the air intake tube then one of the following 3 options apply.

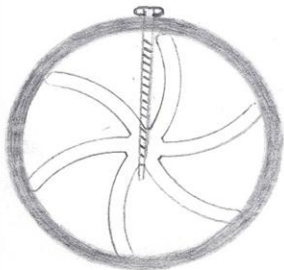
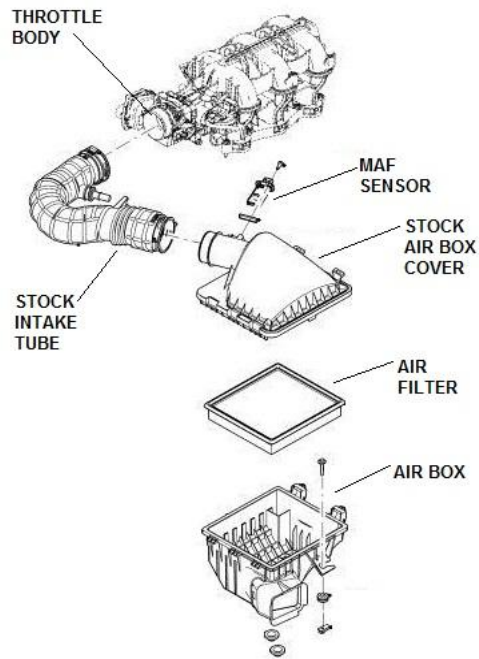

- a) If your intake tube has an inside diameter of 4 inches, the Economaxx is installed using 2 screws. Remove intake tube. Drill two 5/32 inch pilot holes, one from the top and one from the underside of intake tube. Remove all plastic shavings. Insert Economaxx so that small end is facing the throttle body. Fasten Economaxx into place using the hardware provided so that the screws are centered between two fins and travels through the center of the core of the Economaxx. **DO NOT OVER TIGHTEN.** Re-install air intake tube.
- b) If there is **NO** sensor (MAF) in the outlet of the air box cover, remove the cover. Use a 5/32 inch drill bit and drill a pilot hole in the hard plastic outlet of air box cover. **REMOVE** all plastic shavings. Insert Economaxx so that small end is facing the throttle body. Fasten Economaxx into place using the hardware provided so that the screw is centered between two fins and travels through the center of the core of the Economaxx. **DO NOT OVER TIGHTEN.** Reinstall air box cover.
- c) If there **IS** a sensor (MAF) in the outlet of the air box cover, **REMOVE** the air intake tube. Using a 5/32 inch drill bit, drill a pilot hole in the smooth part of the hard plastic tube ensuring Economaxx is kept as close to outlet of the air box cover as possible. **REMOVE** all plastic shavings. Insert Economaxx so that small end is facing the throttle body. Fasten Economaxx into place using the hardware provided so that the screw is centered between two fins and travels through the center of the core of the Economaxx. **DO NOT OVER TIGHTEN.** Reinstall air intake tube.

If you have any installation questions or concerns please visit our website

<http://fuelgeniesolutions.com/installation.php> or call our tech line at 1-519-477-2421.

**DISCLAIMER: Economaxx/The Fuel Genie Corporation/Fuel Genie Solutions will not at any time be held liable for any damages that may occur as a result of incorrect installation.**